

# Cortex™

Prefinished Weatherboards



## A Natural Advance in Cladding

From our Forests to your Home



The mark of  
responsible forestry  
SGS-COC-0889  
© 1996 Forest Stewardship Council A.C.



Integrated. Genuine. Innovative.

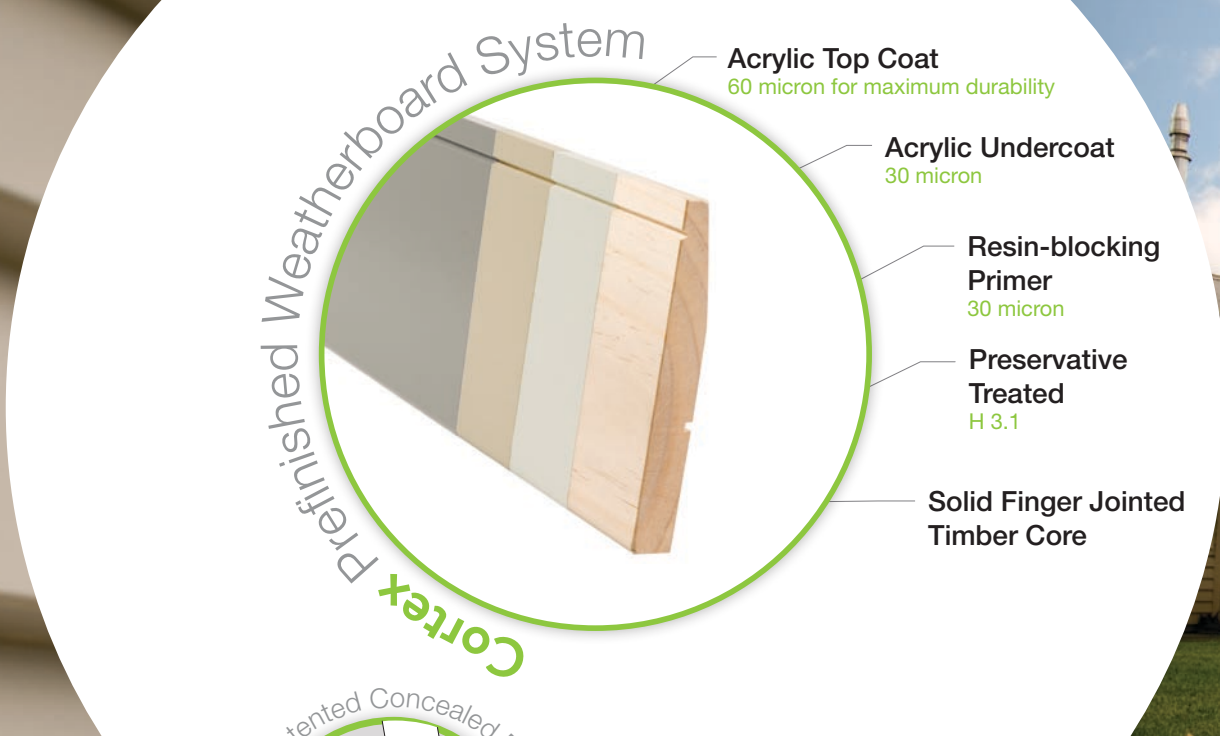

For a gallery of images visit:  
<http://www.pwp.co.nz/product/cortex/gallery.html>

# Cortex is a factory painted Timber weatherboard system

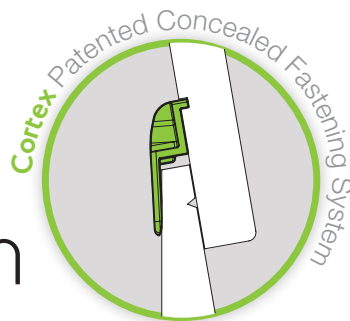

The Primer, Undercoat and Two Acrylic Topcoats are applied in the factory under controlled conditions. Cortex has made a big deal about bringing you the best paint coating because it is the primary weather barrier and the first thing you see on your home.

## Why Pre-Finish?

All painted cladding systems rely on the paint to protect the substrate from harsh sun and weather. The traditional method of applying a coating whilst the board is on a home means your home gets an inconsistent coating that is very reliant on the surface preparation and application method. This affects the durability of the finish and may mean more maintenance.

Cortex is designed to reduce maintenance and deliver you a lasting finish. Our factory applied Acrylic Coating System™ (ACS) delivers a consistent 120 microns of dry film thickness to the exposed surfaces of each board. This ensures each board delivers consistent performance across its lifespan. The ACS finish delivers a good looking, smooth finish that manual application can't match.

## Installation

Our approved install service provides support in the selection and final choice of colour. We also provide guidance on safe durable colours. Over many years the ultra violet spectrum in sunlight breaks down the acrylic resins in all paints, which causes fading and reduces the thickness of the paint coatings. This is common to all painted surfaces regardless of product performance claims.

## Our Advanced Coating System (ACS)

Our Advanced Coating System (ACS) provides extended durability, whilst our installation system provides protection that exceeds any wind rated area in New Zealand, in fact our testing has proven that it is stronger than a typical house frame. This provides you with the best finished weatherboard, and reduces your maintenance and cost of ownership without compromising on style. Cortex has a solid, engineered, preservative treated timber core. It is a natural advance on the traditional bevel back weatherboard system that has successfully clad New Zealand homes for over a hundred years.

## Innovative Assembly System

Cortex effectively re-launches the traditional timber weatherboard onto the market with a smarter and more sophisticated approach. To deliver a pre-finished weatherboard we had to create an innovative assembly system that includes a unique fastening system, a weathertight concealed joint, and an improved corner jointing system. The Cortex system also comes complete with scribes, cavity closers and flashings. The system is fully documented to enable easy specification and compliance for everyone in the approval circuit.

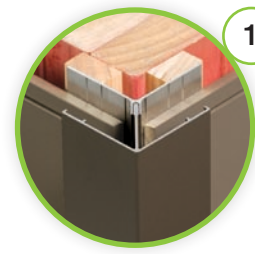

Cortex External Corner Joint



Cortex Cavity Closer



Concealed Fastening System



Cortex Concealed Vertical Joint



Cortex Internal Corner Joint disassembly

### 1. External Corner Joint

The corner joints provide a modern interpretation of a boxed corner. Internal and external corners are given a contemporary new look with aluminium extrusions which finish the system and add another layer of protection for at-risk junctions. By transferring the traditional design into 6061 aluminium we have improved the weathertightness and created a more elegant solution by reducing the section width by half.

### 2. Improved Flashings

Along with these key innovations we have also replaced other flashings with new designs after testing existing systems. The new flashings provide improved weathertightness and moisture management whilst creating a streamlined installation.

### 3. Concealed Fastening System

The concealed fastening system eliminates any exposed penetration of the 120 micron finish ensuring that the finish retains its integrity. The system uses an innovative engineered nylon bracket and a 6 gauge screw. The screws and brackets combine to offer better board to board assembly and installation whilst the 300mm spaced diamond fixing pattern, dramatically increases strength and wind resistance over existing nailed systems.

### 4. Concealed Vertical Joint

The concealed vertical joint provides maximum flexibility without the risk. It creates a seamless joint that is also weathertight. This solution protects against moisture ingress and uses two rear brackets on either side of the joint to provide stability and strength.

### 5. Internal Corner Joint

A tidy solution to an area often forgotten. Consistent treatment is delivered with internal corners to match the elegance of external corners.

## FAQs

### Why is Cortex lower maintenance?

Most weatherboards need to be painted every 7 years; Cortex is guaranteed\* maintenance free (excluding wash-downs) for a period of 10 years due to its consistent 120 micron dry film thickness, concealed fixing system, and integrated accessories delivering superior weather resistance.

### Can I paint over Cortex?

You sure can, ACS is an acrylic system and can be painted over with all major paint systems without diminishing the underlying 'Factory Finish'.

### Can I touch up Cortex?





Yes, just like any other cladding product it can be touched up if there is superficial damage, in fact we even give you a test pot in case the need arises.



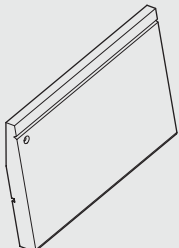

## Cortex® Timber Components



For complete technical specifications visit:  
<http://www.pwp.co.nz/product/cortex/downloads.html>

			
<p><b>Cortex™ Bevel Back Weatherboard</b>            140 x 18 mm (110 mm Cover)            Material: Engineered Solid Core Radiata Pine, H3.1, Cortex ACS™ Prefinished</p>	<p><b>Cortex™ Cavity Batten</b>            Material: Engineered Solid Core Radiata Pine, H3.1, Cortex</p>	<p><b>Cortex™ Timber Corner Scriber</b>            Material: Engineered Solid Core Radiata Pine, H3.1, Cortex ACS™ Prefinished</p>	<p><b>Cortex™ Timber Window Scriber</b>            Material: Engineered Solid Core Radiata Pine, H3.1, Cortex ACS™ Prefinished</p>

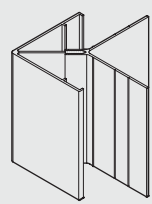
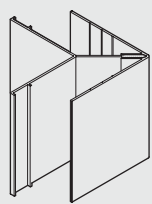
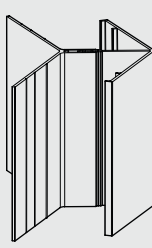
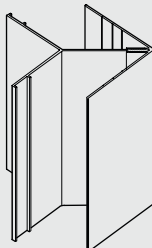
## Cortex® Corner Jointing Components

			
<p><b>Cortex™ External Corner Joint</b>            Material: Aluminum 6060 T5 Cortex ACS™ Prefinished</p>	<p><b>Cortex™ Internal Corner Joint</b>            Material: Aluminum 6060 T5 Cortex ACS™ Prefinished</p>	<p><b>Cortex™ 135° External Corner Joint</b>            Material: Aluminum 6060 T5 Cortex ACS™ Prefinished</p>	<p><b>Cortex™ 135° Internal Corner Joint</b>            Material: Aluminum 6060 T5 Cortex ACS™ Prefinished</p>

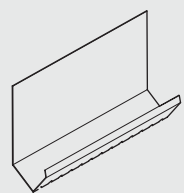
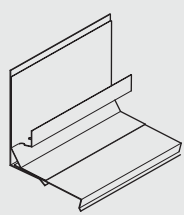
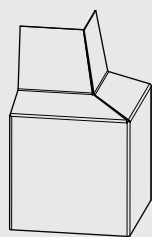
## Cortex® Flashings, Terminations & Transitions

			
<p><b>Cortex™ Cavity Closer</b>            Material: Galvanized Steel 0.55mm</p>	<p><b>Cortex™ 2-part Head Flashing</b>            Material: Galvanized Steel or Aluminium 0.55mm</p>	<p><b>Cortex™ External Termination</b>            Material: Galvanized Steel 0.55mm</p>	<p><b>Cortex™ 2 Part Material Transition</b>            Material: Galvanized Steel or Aluminium 0.55mm</p>

## Cortex® Plastic Components

		<p><b>Cortex™</b>            Prefinished Weatherboards</p> <p>PHONE 0800 CORTEX OR (06) 834 34 35            EMAIL <a href="mailto:sales@cortexcladding.co.nz">sales@cortexcladding.co.nz</a>            WEB <a href="http://www.cortexcladding.co.nz">www.cortexcladding.co.nz</a>            ADDRESS 65 Thames Street, Napier, NZ</p>
<p><b>Cortex™ Concealed Fastening Clip</b>            Material: Zytel 101F Nylon</p>	<p><b>Cortex™ Vertical Joint</b>            Material: Polypropylene</p>	